

# NAUTILUS HD

5/RED

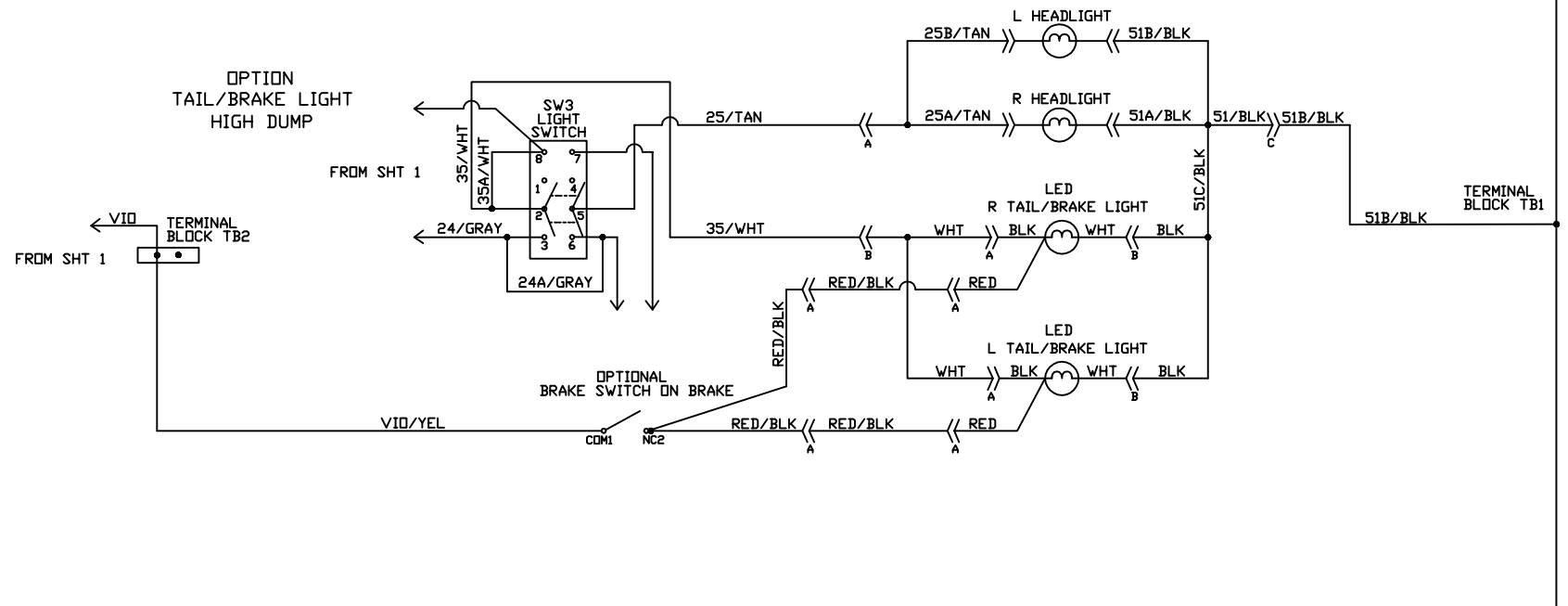
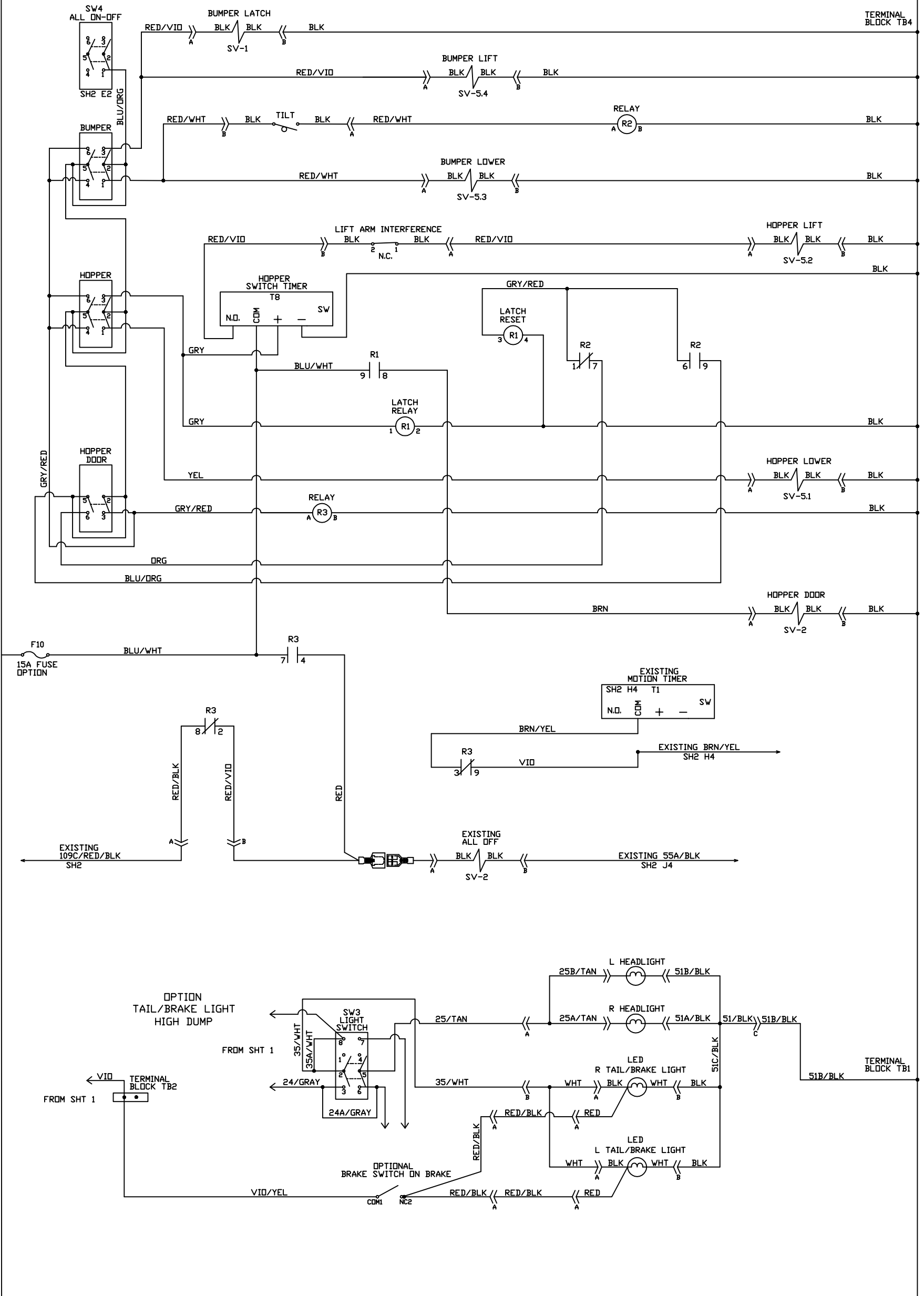

<b>CONFIDENTIAL</b>									
THIS DRAWING AND ALL INFORMATION CONTAINED THEREIN ARE THE EXCLUSIVE PROPERTY OF MINUTEMAN INTERNATIONAL, INC. THIS DRAWING IS NOT TO BE COPIED OR OTHERWISE REPRODUCED WITHOUT EXPRESSED WRITTEN PERMISSION OF MINUTEMAN INTERNATIONAL, INC. IN ADDITION, THIS DRAWING MUST BE RETURNED UPON REQUEST. FURTHER, ALL INFORMATION CONTAINED HEREIN MUST BE MAINTAINED CONFIDENTIAL.									
TITLE NAUTILUS ELECTRICAL SCHEMATIC								SCALE NTS	
MATERIAL N/A					FINISH N/A				
TOLERANCES (UNLESS OTHERWISE SPECIFIED)					REMOVE BURRS AND BREAK SHARP EDGES .005/.020				
0-1" ± 1/16		.000 ± .005		SIZE B		DRAWN BY KHH		DATE 08/03/15	
>1-12" ± 1/4"		.00 ± .010		CHECKED BY JWP		DATE 08/03/15			
<12" ± 1/2"		ANGLES ± 30'							
REV E.C.N.		DATE		CHANGE		BY CHK BY		P.N. 748992-1 F	
								SHEET 4 OF 5	

F	150447	10/18/18	ADD BRAKE LIGHTS	KHH	KHH
E	MIN-13575	10/02/17	ADD BLUE LIGHTS & REAR VIEW CAMERA	KHH	JWP
D	MIN-13523	07/28/17	ADD DRY SWEEP OPT & UPDATE LATCH RELAY	KHH	JWP
C	MIN-13367	11/11/16	ADD MTR PMP OPTION, ADD SHEET 5	KHH	JWP
REV	E.C.N.	DATE	CHANGE	BY	CHK BY

**Minuteman**  
 Excellence Meets Clean  
 14N845 U.S. ROUTE 20  
 PINGREE GROVE, IL 60140